

Thrust Washer Design Worksheet

PROVIDE DETAILS IN BOX TO THE RIGHT

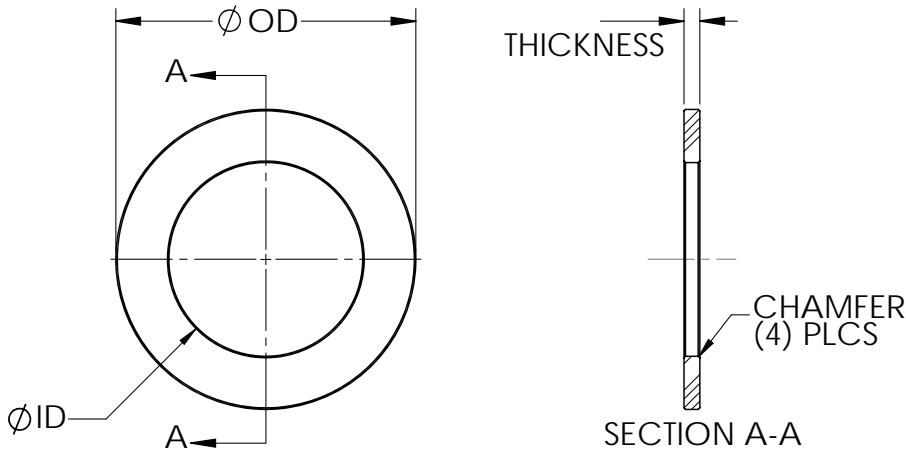

DIMENSIONS

Provide hardware dimensions below.

ID Min _____ /Max _____

OD Min _____ /Max _____

Thickness _____

Additional Notes

CONTACT INFORMATION

Company _____ Name _____
Phone _____ Fax _____ E-Mail _____

HOUSING AND MATERIAL INFORMATION

Sizes are required if dimensions were not provided above.

Housing Size: Min _____ Max _____ Housing Material (required): _____

Shaft Size: Min _____ Max _____ Shaft Material (required): _____

Current Material: _____

ENVIRONMENT

Wet (water): Dry: Caustic: Dusty: Greased: Other: Normal Operating Temperature: _____

OPERATION

RPM _____ Load Weight _____ Hours of Operation/day _____

Rotation

360° Osculating Intermittent: Yes No Frequency/Cycles _____

MANUFACTURING OPTIONS

Raw Material (raw sheet is supplied with additional material allowance for machining)

Semi-Finished (CIP to rough ID/OD)

Finished Machined (CIP to machine complete to design)

ORDER DETAILS

CIP Material: _____ Quantity Needed: _____

CIP Only:

Raw Sheet: _____

Cloth Size: _____

APPLICATION: